

DESIGN VARIANTS – GEA HILGE DURIETTA

Standard variants	Description
GEA Hilge DURIETTA K	Horizontal installation, closed-coupled pump with plug-in shaft
GEA Hilge DURIETTA K-SUPER	Horizontal installation, motor with stainless steel shroud on stainless steel foot, closed-coupled pump with plug-in shaft

TECHNICAL DATA

GEA Hilge DURIETTA	50 Hz	60 Hz
Flow	8 m ³ /h	8 m ³ /h
Head	75 m	42 m
Operating temperature	95 °C	
Operating pressure	max. 8 bar	

PERFORMANCE CURVE 50 HZ

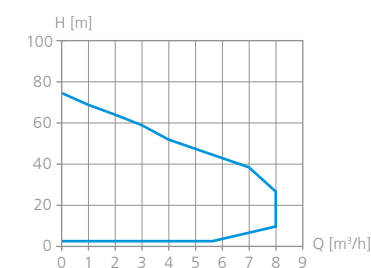

PERFORMANCE CURVE 60 HZ

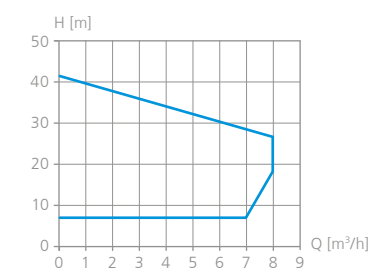

We live our values.

Excellence • Passion • Integrity • Responsibility • GEA-versity

GEA Group is a global engineering company with multi-billion euro sales and operations in more than 50 countries. Founded in 1881, the company is one of the largest providers of innovative equipment and process technology. GEA Group is listed in the STOXX® Europe 600 Index.

GEA Germany
GEA Hilge GmbH & Co. KG
Hilgestraße 37–47
55294 Bodenheim, Germany

Tel +49 6135 7016-0
Fax +49 6135 1737

info@gea.com
gea.com

GEA SMARTPUMP



GEA Hilge DURIETTA

Compact, Single- and Multi-Stage
Centrifugal Pumps for Standard
Applications



Smart, Safe and Compact for your Hygienic Production Processes

The GEA Hilge DURIETTA in the GEA SMARTPUMP line for standard applications is a close-coupled end-suction single- or multi-stage centrifugal pump created for all kinds of applications under hygienic conditions.

The Solid Pump for Applications in the Food and Beverage Industries

The GEA Hilge DURIETTA is designed in compliance with food technology requirements, making it ideal for jobs where hygiene is a key concern. For example, it is CIP- and SIP-capable with the performance characteristics outlined for pumps in DIN 12462. The unique hygienic design and the deep-drawn, rolled stainless steel AISI 316L make the GEA Hilge DURIETTA pump range suitable for:

Food & Beverage

- Microbreweries and dairies
- Bottling systems
- Food processing plants
- Drinking water systems
- CIP systems

Pharmaceutical and Related Industry

- Personal care industries
- CIP systems

Other Industrial Applications

- Semi-conductor manufacturing
- Heat exchangers

Mechanical Shaft Seal

GEA Hilge offers various seal arrangements:

- Single mechanical seal
- Double mechanical seal (tandem)

The standard mechanical shaft seal has an optimum position in the pump housing. This ensures lubrication, cleaning and cooling of the mechanical seal in accordance with the criteria of hygienic design.



FEATURES AND BENEFITS

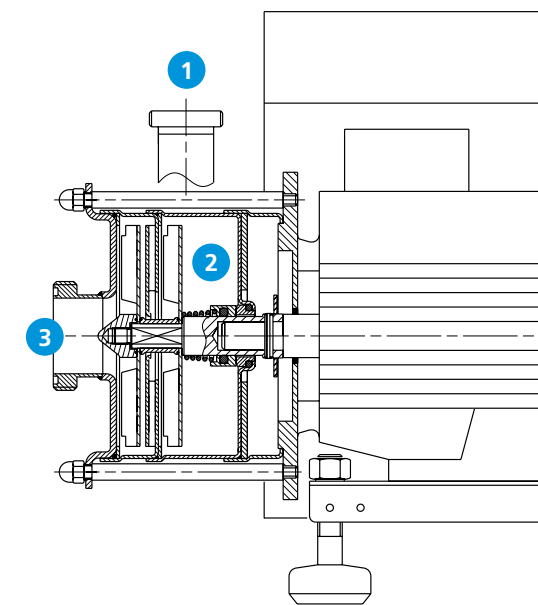

1 Connections

Various nominal widths and connections

2 Shaft seal

Optimal position in the pump housing

3 Surface

Electro-polished for easy cleaning

Connections

GEA Hilge offers threads to DIN 11851 as standard for GEA Hilge DURIETTA pumps.

Connections on Request

Threads:

- Threads SMS
- Threads DIN 11864-1

Flanges:

- Flanges EN 1092-1 (DIN 2642)
- Flanges DIN 11864-2

Clamps:

- Clamps TRI-CLAMP

Other connections are available on request.



GEA Hilge DURIETTA K-SUPER

Impeller

The GEA Hilge DURIETTA has semi-open impellers, which allows easy and sufficient cleaning.

The GEA SMARTPUMP Line for your Standard Applications

The GEA Hilge DURIETTA pump in the GEA SMARTPUMP line is the right choice for your applications under hygienic conditions. The range of these single- and multi-stage sanitary pumps allows you to choose between several standard variants to suit your task.