

GEA VARIPUMP



GEA Hilge HYGIA

Single-Stage End-Suction Centrifugal Pumps
for Advanced Applications

More Flexibility for your Demanding Process Applications

The premium pump series GEA Hilge HYGIA in the GEA VARIPUMP line consists of single-stage end-suction centrifugal pumps, constructed for use in industries with high demands to hygiene and flexibility.

Corresponds to the Highest Global Hygiene Requirements

Produced of high-quality materials that meet the highest global hygiene standards, GEA Hilge HYGIA also offers a high level of flexibility. Apart from DIN, ASME and ISO connections, a flexible range of custom connections is available upon request.

The pumps are equipped with operating-point-optimized impellers. Different impeller geometries are available for this.



GEA Hilge HYGIA Adapta-SUPER

DESIGN VARIANTS – GEA HILGE HYGIA

Standard variants	Description
GEA Hilge HYGIA Adapta	Close-coupled pump with bearing bracket and coupling, horizontal installation
GEA Hilge HYGIA Adapta-SUPER	Close-coupled pump with bearing bracket and coupling, horizontal installation, motor with stainless steel shroud
GEA Hilge HYGIA K	Close-coupled pump with plug-in shaft connection, horizontal installation
GEA Hilge HYGIA K-SUPER	Close-coupled pump with plug-in shaft connection, motor with stainless steel shroud, horizontal installation
Variations upon request	Description
GEA Hilge HYGIA tronic	Motor with built-in frequency converter (up to 22 kW)

TECHNICAL DATA

GEA Hilge HYGIA	50 Hz	60 Hz
Flow	110 m ³ /h	110 m ³ /h
Head	70 m	90 m
Operating temperature	up to 95 °C (150 °C upon request)	
Sterilization temperature	up to 140 °C (SIP)	
Operating pressure	PN 16 (PN 25 upon request)	

PERFORMANCE CURVE 50 HZ

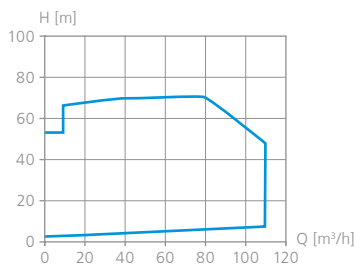

PERFORMANCE CURVE 60 HZ

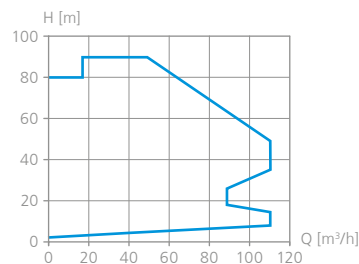



FEATURES AND BENEFITS

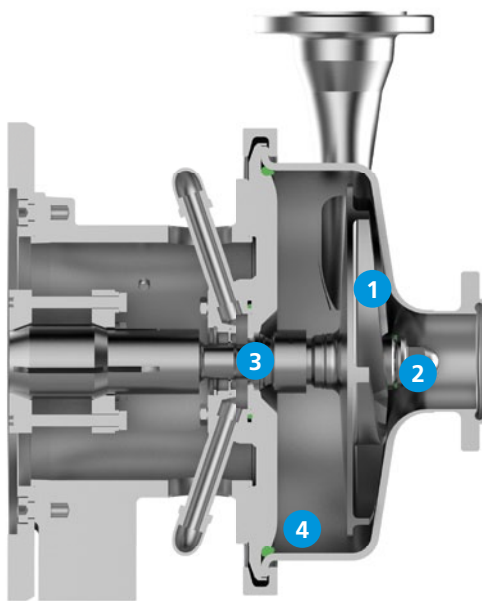

1 Optimized impeller

Open and closed impellers available as well as free-flow impellers

2 Hygienic construction

The constructional design allows optimal cleaning (CIP) and sterilisation (SIP)

3 Inboard mechanical seal

For effective cleaning, cooling and lubrication

4 Dead end free design

The pumps meet the highest hygienic demands to avoid contamination

The GEA Hilge HYGIA pump can be flexibly employed in all application ranges in which reliable hygienic pump function is required. This includes the following areas:

Food & Beverage Industry

- Beer/breweries
- Dairies
- Soft drinks
- Yeast processing

Life Science/Pharmaceuticals Industry

- Pumping of sterile and pure water (WFI)
- Biotechnology
- Infusions (nutrient solutions, alcohol)
- Filling stations

Personal Care

- Purified water, WFI
- Lotions
- Perfumes

Additional Industrial Applications

- Cleaning processes (CIP systems)
- Water technology processes
- Semiconductor production
- Metal surface treatment
- Bio fuel
- Water treatment systems
- Textile industry
- Paint systems



Suitable for the Highest Standards

The materials used for GEA Hilge HYGIA pumps have been selected for the use in hygienic processes. The housings are made of CrNiMo rolled steel (1.4404/1.4435) and have a smooth surface without pores and blowholes.

Certification-Compliant

GEA Hilge HYGIA pumps are CIP/SIP-able according to the performance criteria for pumps acc. to DIN EN 12462. The media-contacting parts meet the requirements of the QHD-standards and the EHEDG with test certificate as proof of CIP cleaning capacity.

Mechanical Seals – Choose the One to Suit You

A wide range of mechanical seal options is available to suit different media and applications. The mechanical seals used in the GEA Hilge HYGIA range are single inboard seals that maintain the optimum position in the liquid.

Choices Include

- Single mechanical seals in sterile execution
- Double mechanical seals (tandem or back-to-back)
- Standard seal face material: carbon/stainless steel and SiC/SiC
- Standard O-ring material: EPDM (FDA-compliant)
- Additional designs and materials available upon request





We live our values.

Excellence • Passion • Integrity • Responsibility • GEA-versity

GEA Group is a global engineering company with multi-billion euro sales and operations in more than 50 countries. Founded in 1881, the company is one of the largest providers of innovative equipment and process technology. GEA Group is listed in the STOXX® Europe 600 Index.

GEA Germany

GEA Hilge GmbH & Co. KG
Hilgestraße 37–47
55294 Bodenheim, Germany

Tel +49 6135 7016-0
Fax +49 6135 1737

info@gea.com
gea.com